

[The How-To Geek Guide to Buying the Right Printer](#)



Even though computer printers are relatively ubiquitous, you can't just go pull one off the shelf and be guaranteed a good fit for your needs. Read on as we detail the ins and outs of buying a home printer.

Know Your Printing Needs

The first step in printer-shopping nirvana is to start your search with a very clear picture of what your printing needs are. Think back over what you've printed lately and what you plan to print in the future. Do you print mostly black and white text copies? Color photos? Color proposal drafts for your home business? What kind of printing you do is the biggest factor in what kind of printer you should shop for. The key is to buy a printer for the work you're doing, not the work you think you might be doing in the future (in other words: buy the printer for the business reports you print now, not the colorful scrap book pages you wish you had time to work on).

Understanding Printer Technology



The core of any printer is the technology driving the actual print process. The mechanics of printing can involve blasts of ink, powder toner, electrostatic charges, or any other number of combinations to produce an image. We're going to detail the major technologies on the market with their benefits and short comings.

Ink Jet: Ink jet printers are everywhere. Consumers frequently get them free with desktop computer packages, you'll find basic models all over big box computer and office stores at dirt cheap prices, and they've enjoyed a fairly strong home-user market saturation.

At its most basic, ink jet printer technology is based on tiny little nozzles squirting a fine mist of ink onto paper. There are microchips in the print cartridges and an elaborate electro-mechanical framework supporting that process, mind you, but it's still akin to tiny little cans of spray paint working down the page.

The popularity of ink jet printers can be largely attributed to their versatility. Although low-end ink jet printers aren't the best at any specific type of printing they are great at doing a good-enough job for many types of printing (currently high-end ink jets and desktop photo printers based on ink jet technology dominate the consumer photo market).

They can print plain black and white documents, color photos, and print on a variety of media that other printers simply can't match. Since the ink is sprayed down on the surface, isn't heated, and (using the pass-through tray) it isn't bent or rolled, it's possible to use all sorts of media in most ink jet printers ranging from photo paper to specialty stocks like canvas and T-shirt transfers.

On the downside: ink jet printers are notoriously slow and the quality varies wildly. If you routinely print off multi-page reports and you want them hot off the press, you'll be waiting awhile as your ink jet printer labors through them. The quality of the print is also dependent on what kind of ink and paper you're using. Business-oriented ink jet printers tend to use pigment-based inks which are superior for crisp lines and graphics (like the fonts and company logos you find in most business printing). Ink jets that advertise superior photo printing usually use dye-based ink that blends much smoother—thus your photos look more realistic with better colors. With many brands it is possible to buy ink cartridges for both purposes but it's less than ideal to swap out cartridges for different printing tasks.

The biggest downside of inkjet printing, by far, is the cost. You can easily pick up an inkjet printer for under \$100 but consider that a company-subsidized bargain. They know you'll be back for expensive cartridge-after-cartridge. Yes you can buy third-party cartridges and yes you can buy home-refill kits. A casual search online will show there are many people happy with such options—unfortunately it voids your warranty and refilling old cartridges is a hassle.

The Final Verdict for Ink Jet Printers: If you need to print on a wide variety of materials (labels, transfer paper, glossy paper, regular printer paper, etc.) and you're not afraid of the higher supply cost incurred by frequently replacing ink cartridges, ink jet printers are a versatile addition to a home office.

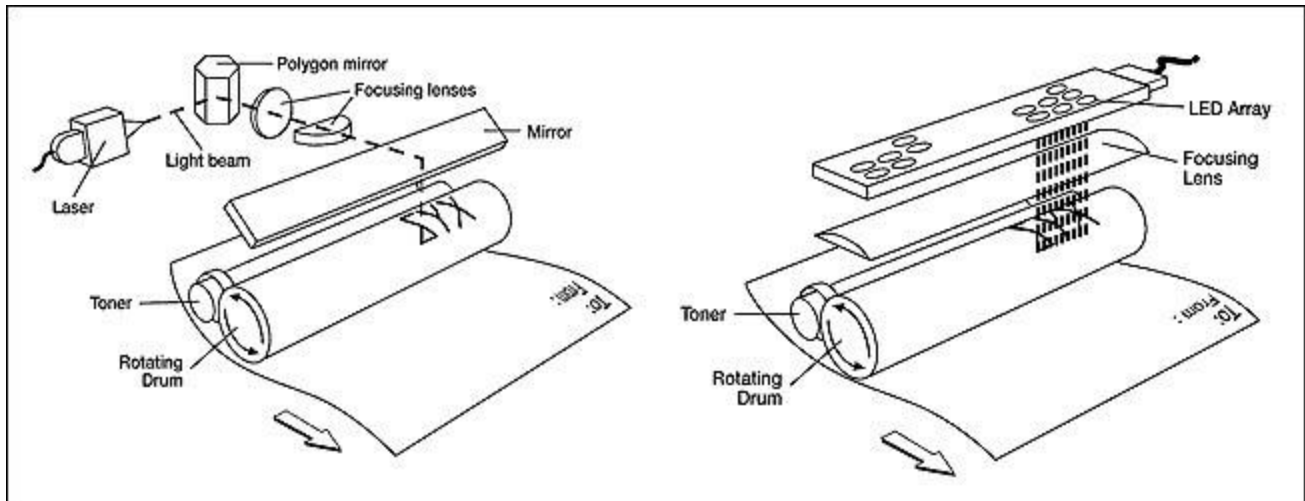

Laser/LED: Laser printers, unlike ink jet printers, do not rely on a supply of ink and a small spray nozzle to deposit it onto the page. Laser printers function much more closely to photo copiers than they do to ink jet printers. An electrostatic charge is applied to the paper which is then passed over a toner drum (toner is an ultra-fine powdered carbon and polymer blend) which is then fused onto the paper with heat. This is why a drop of water doesn't ruin a laser printer printout the way it does a page from an inkjet printer—the toner is fused right onto the paper.

Speed and economical operation are the strongest selling points for laser printers. While ink jets can print on a variety of media with different inks in different colors, laser printers are monochromatic and limited to a much smaller range of media that can withstand the heat of the fusing process. (There are now color laser printers in the consumer price range but the color toner refills remain prohibitively expensive and keep color laser printing out of reach for most home users.)

An additional benefit of laser printing: the toner is dry and you can go months (if not years) without printing and the next print off the printer will look just as good as the first. In that same time span ink jet cartridges can dry up, the nozzles can get gummed up/crusted over, and you may find yourself hastily shopping for new cartridges. We've pulled old laser jet printers out of office storage and fired them up after years of neglect and they've printed like they were brand new.

A recent addition to the market, LED printers are essentially super-charged laser printers. Whereas a laser printer relies on an elaborate array of moving mirrors and focusing lenses (all of which must be in alignment) to generate the image on the toner drum, LED-based printers have a solid-state array in place of the laser array (thus there are no moving lasers, lenses, or mirrors to keep in alignment).

Currently you'll pay a small premium for an LED-based printer over a laser-based one but in return you'll get a potentially faster printer (LED units render the whole width of the drum image at the same time instead of scanning across with the laser) that's less prone to breakdown because the LED array is solid-state. That said, we have laser printers around the office that have

been going strong since the 1990s—even with the scanning laser/moving mirrors they are still much more reliable than ink jet printers.

The Final Verdict on Laser/LED Printers: If your primary printing needs are black and white text prints with occasional supplemental images, print-for-print you can't beat a laser/LED printer. Your printer will last longer, spool up faster, and cost you less per-print than an ink jet by a wide, wide margin. How wide of a margin? We've replaced the toner cartridge in our HP Laserjet only twice since 1999—that's 12 years of printing for about \$100 worth of toner.

Printer Features, Terms, and Jargon

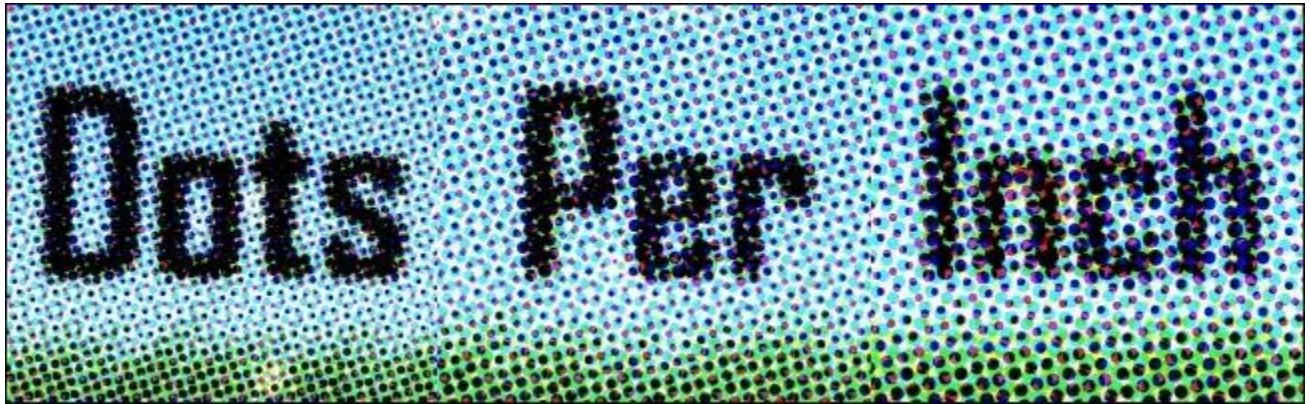

For the home user the two printing types we outlined above, ink jet and monochrome laser/LED, are the two best things going—color laser printing is still too expensive for casual home use. Once you've narrowed down which type of printer you're interested in, however, you've still got a mountain of features and terms to wade through. We'll do our best to help hack down the dictionary of terminology to a manageable list.

One note before we dig into the terms, manufacturers can (and often do) play fast and loose with the marketing terms they use. When in doubt, read consumer reviews about your printer before purchasing.

Resolution/DPI: You'll see references to DPI all over the place while printer shopping. DPI stands for Dots-Per-Inch and it indicates how many individual dots of ink or toner are deposited within one square inch of printable area. Please note that the Dots-Per-Inch nomenclature for printing is completely different than the Pixels-Per-Inch nomenclature used with monitors—a computer monitor can produce radically more detail/vibrant color with fewer pixels because of the nature of monitor construction and the superior color rendering of pixels versus printed ink.

While historically the DPI was worth paying attention to, printing technology has improved so much in recent years that the DPI number largely irrelevant. 150 DPI is an acceptable level for simple draft prints (like grocery lists), 300 DPI is more than fine for sharp fonts and logos, and as you creep into higher DPI you get an even better print. Low-end ink jet printers typically have 300-600 DPI printing capabilities and higher-end inkjets easily climb past 1,000 DPI. Laser/LED printers range anywhere from 600-2,000+ DPI. Unless you're specifically buying a printer for

printing photos at home you can safely ignore the DPI rating all together as even the lowest end printer on the market will put out more than enough DPI for your letter/brochure/report printing needs.

Printing Speed: Although almost always expressed as PPM (pages per minute) you may also see printing speed notes as CPM (characters per minute) or, if you're shopping for photo printers, IPM (images per minute). If you're comparing ink jets with laser printers you'll see a vast difference between PPM ratings. Ink jet printers are significantly slower than laser printers and manufacturers try to inflate the low PPM of ink jet printers by putting the draft-pages-per-minute on the box and in the printer specs—be aware of this and half the PPM rating to get a better idea of the rate for high-quality prints.

Regard the printing speed as a ball park figure. Your real-world PPM will vary widely from the manufacturer's numbers based on what kind of printing you do (book report type prints on a laser printer, for example, will practically fly into the print tray where photos on an inkjet might well be dry by the time they finish).



Connection Types: Long gone are printers that connect via serial or parallel ports; the current standard for wired connections is USB. Some printers, especially laser/led printers, come with a network jack for network-based printing. More and more printers are shipping with built-in Wi-Fi functionality. If you're interested in putting your printer somewhere else besides directly next to your primary computer, network and/or Wi-Fi printing can be invaluable. It makes it super simple to put your printer out of the way and still be able to shuttle prints to it from your desktop, laptop, and mobile devices without the need for print-sharing service on your primary desktop.

Internal Memory: Depending on the type of printer you buy it can have anywhere from a tiny amount to half a GB or so. Single function consumer inkjet printers usually have negligible amount of internal memory (multi-function ink jet printers will have more internal memory to support the print process and secondary functions like scanning). Laser printers generally have larger amounts of internal memory (ranging from 128-512MB). Generally speaking networked/Wi-Fi enabled printers will have the most memory as it allows them to handle the

extra print jobs coming in from across the network. Unless you plan on printing a large volume of material in a small time frame and/or to have a lot of material come in over the network, you don't need a large memory bank in the printer. If you're worried about it, check to see if the printer has an upgrade slot for future memory upgrades. Such upgrade slots are next to non-existent on low-end ink jets but quite common on laser printers.



Multi-Function/All-In-One: Multi-function printers combine additional features into the body of the printer. Many models combine a scanner and printer, to create a tiny home copy machine. Others also include fax capability and even phone handsets. The upside is that it's usually way cheaper to buy a multi-function printer than it is to buy a printer, scanner, and fax machine. The downside is that if any component fails the whole unit can fail (or at minimum, need to be sent in for service).

When they work well, they're great and they save a lot of space. When they fail, they take out a whole chunk of your home office functionality with them. We tend to avoid multi-function units but if you find a great deal on one and you're willing to accept the risk of putting all your eggs in one electronic basket, it might be worth the trade offs. If you're leaning towards an All-In-One model make sure to read as many reviews as you can before purchasing it—you want to be sure to get one few people have had issues with.



Stand-Alone Printing: Whether they call it Stand-Alone, Walk-Up, PC-less, or another term, many printer companies now include functionality that allows for printing without a computer. Essentially you can walk up with a USB drive, SD card, or other type of removable media, plug it into the printer, and print from the flash memory instead of by sending the file from a computer. All things considered it's kind of a one-trick pony. We certainly wouldn't buy a printer just for this feature. Where the feature does shine, however, is for stand-alone photo printers. It's quite convenient to stick the SD card or link the camera via cable to the printer for pick-and-print photo printing.

Monthly Duty Cycle: The duty cycle is an often overlooked stat on the printer spec sheet. The duty cycle is essentially a pages-per-month rating. If the stats for the printer you're looking at indicate that the duty cycle is 1,000 pages per month, the manufacturer is essentially saying that you can expect to print up to that volume per month without any issues. You want to purchase a printer with a monthly duty cycle well beyond your needs to ensure trouble free operation. Printers with higher duty cycle ratings are built sturdier to survive the wear and tear of heavy printing.

By purchasing a printer with a duty cycle beyond what you actually need you decrease the chances of prematurely wearing the printer out. Remember that laser jet printer that has been going strong since 1999 that we mentioned earlier in the guide? It has a duty cycle rating of 10,000 pages per month—we're pretty sure we've put less than a quarter of that through it *a year*. It will fall prey to antiquated cable formats and interfaces long before it gives up the printing ghost.



Duplexing: Duplexing is a fancy word for prints-on-both-sides. Printers without duplexing are stuck with manual duplex—which in turn is a fancy way of saying that you'll need to take the one-sided sheets and feed them back into the printer in the right order for a proper two-sided printout. Manually duplexing is an enormous pain and not something you want to do with any regularity. Whether you want to save paper or like a thinner stack of print outs, make sure you get a printer that can properly duplex without you having to do the print-out shuffle every time you want two-sided prints.

Manual Feed/Multi-Purpose Tray: If you print a lot of card stock, envelopes, or (for ink jet printers) any kind of non-traditional stock like thick scrap book pages or T-shirt transfers, make sure you purchase a printer with a manual feed tray and/or multi-purpose tray. This allows you to by-pass whatever paper-manipulation the printer normally performs and send the media straight through the printer without any bending or excessive rolling. Since a business envelope would never make it through the roller system of a laser printer, for example, it's important to have a manual feed tray to send the envelope right in the front and out the back without any bending.

Consumables: Every printer consumes something—ink cartridges, toner cartridges, paper types, etc.—when shopping for a printer make sure to do a phantom shopping trip to restock it. That \$50 ink jet printer isn't much of a bargain if it uses tri-color cartridges that cost \$40 each and need to be replaced as soon as one of the three colors has run dry.

When shopping for ink jet printers make sure to check out what kind of cartridge system it uses. Can you replace each color individually? Are the black cartridges economical? If you're comfortable voiding the warranty with aftermarket cartridges and ink refills are they readily available and easy to use?

When shopping for laser/LED printers make sure you can replace just the toner drum. Some companies require that you replace the entire toner/fuser assembly when the drum runs dry—this will significantly up your consumables cost over the life of the printer.

If you start by first focusing on your primary printing needs (bulk black and white versus black and white mixed with color), then on the significant features you want (duplexing and Wi-Fi support), and finally comparing models to squeeze out those last whizz-bang features (perhaps a touch screen interface and Cloud Print support), you'll ensure you end up with a printer that meets your most critical needs first and makes printing more enjoyable with well-picked secondary features.